



MT1570 DOCSIS® 3.0 Upstream Amplifier

DESIGNED FOR DOCSIS 3.0 AND DOCSIS 2.0 MODEMS REQUIRING HIGH TRANSMIT POWER..

Related Product Information:

- [Press Release](#)
- [Related Products](#)
- [Order Information](#)
- [Cable Product Selector Guide](#)

DESCRIPTION

The MicroStreamer™ MT1570 is a low-cost, programmable power amplifier IC that has been developed specifically for use in CATV upstream applications. This amplifier can be combined with the MT2170 tuner to create a complete RF front end for DOCSIS 3.0-compatible cable modems and gateways. The MT1570 supports four bonded upstream data channels to be simultaneously transmitted in accordance with DOCSIS 3.0 requirements.

The MT1570 meets all DOCSIS requirements with outputs as high as 64 dBmV for a QPSK modulated signal. A 3-wire digital serial bus is used to program the variable gain in 1 dB steps over a nominal range of 63 dB.

The IC operates from a nominal supply voltage of 5.0 V and dissipates a maximum of 2.2 W at the highest gain setting and power settings. The MT1570 has programmable current modes that can be used to adjust the bias current of the output stage resulting in reduced power consumption. This is useful in applications that can tolerate reduced linearity.

The MT1570 can be shutdown via an external control pin or via the 3-wire serial bus. In this mode the IC draws less than 150 μ A while retaining its previously programmed gain and current mode state. A Transmit Disable mode turns off the output stage while maintaining the nominal output impedance. Current draw is less than 30 mA in this mode.

The MT1570 is housed in a 20-pin Quad Flat No-Lead (QFN) package with an exposed paddle for improved thermal dissipation. This allows it to be used in applications with a temperature range of -40 °C to +85 °C. The MT1570 is compliant with the RoHS directive for the restriction of the use of certain hazardous substances in electrical and electronic equipment..

APPLICATIONS.

- DOCSIS 3.0 Cable modems and gateways
- Telephony over CATV

- High-power DOCSIS 2.0 cable modems
- CATV Set-top boxes

FEATURES

- High impedance input
- 5 Volts power operation
- 64dBmV output power
- High gain greater than 32 dB
- Large gain range of 63 dB
- 1 dB step size

- Low transmit NF
- Low output noise in disable mode
- Temperature range of -40°C to +85°C
- DOCSIS 1.0, 1.1, 2.0, 3.0, and Euro-DOCSIS™ compatible
- 20-pin, 5 mm x 5 mm QFN package

AMPLIFIER CHARACTERISTICS

Figure 1 MT1570 Block Diagram

Absolute Maximum Ratings

Parameter	Min	Max	Unit
V _{CC}	-0.7	6.0	V
Input common mode voltage levels (all inputs)	-0.7	V _{CC} + 0.7	V
Junction temperature		125	°C
Storage Temperature range	-40	150	°C
Lead free solder temperature for 5 seconds, x3		260	°C
Relative humidity		85	%

Electrical Characteristics

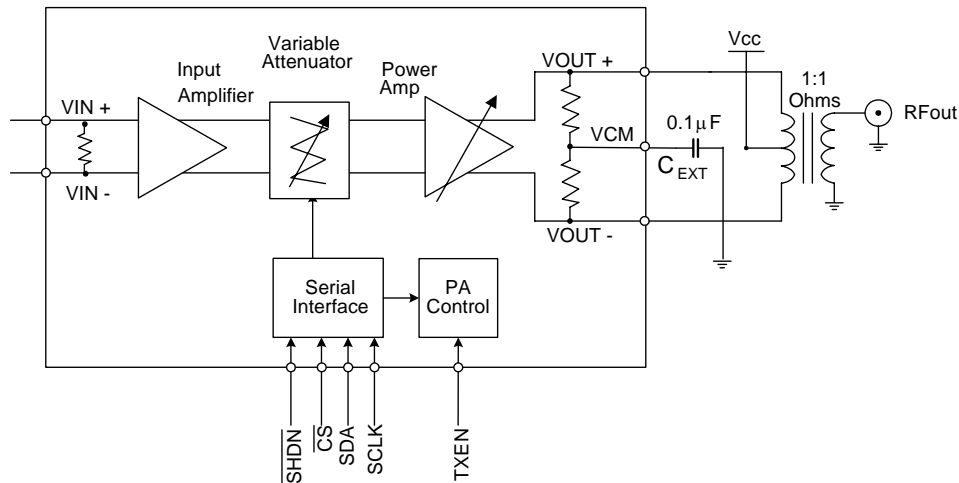
Parameter	Min	Typ	Max	Unit
Power supply voltage	4.75	5.0	5.25	V
Power supply ripple, DC-500 KHz			25	mV _{p-p}
Power dissipation; gain code 63, current mode 3		1.9	2.2	W
Power dissipation; gain code 0, current mode 3		0.5		W
Supply current: transmit-disable mode		25	30	mA
Supply current: shutdown mode		60	150	μA
Voltage Gain, gain code 63	32	33.5	35	dB
Digital input high voltage	1.5		3.6	V
Digital input low voltage			0.8	V
Digital input current		0		μA

Environmental Requirements

Parameter	Min	Max	Unit
Ambient operating temperature		85	°C
Die temperature		125	°C
Relative humidity @ 40 °C ambient		85	%

Related Documents

- PB-00156 MT1570 Product Brief (This Document)
- DS-00105 MT1570 Data Sheet
- AN-00010 MicroTuner™ Series Application Note for Serial Bus Interface
- AN-00043 Surface Mount Assembly of Quad Flat No-lead (QFN) Packages
- AN-00076 Thermal Design Considerations Application Note
- BM-00236 EV Board Bill of Material
- GR-00236 EV Board Gerber File
- SC-00236 EV Board Schematic
- UG-00236 EV Board Basic User's Guide.

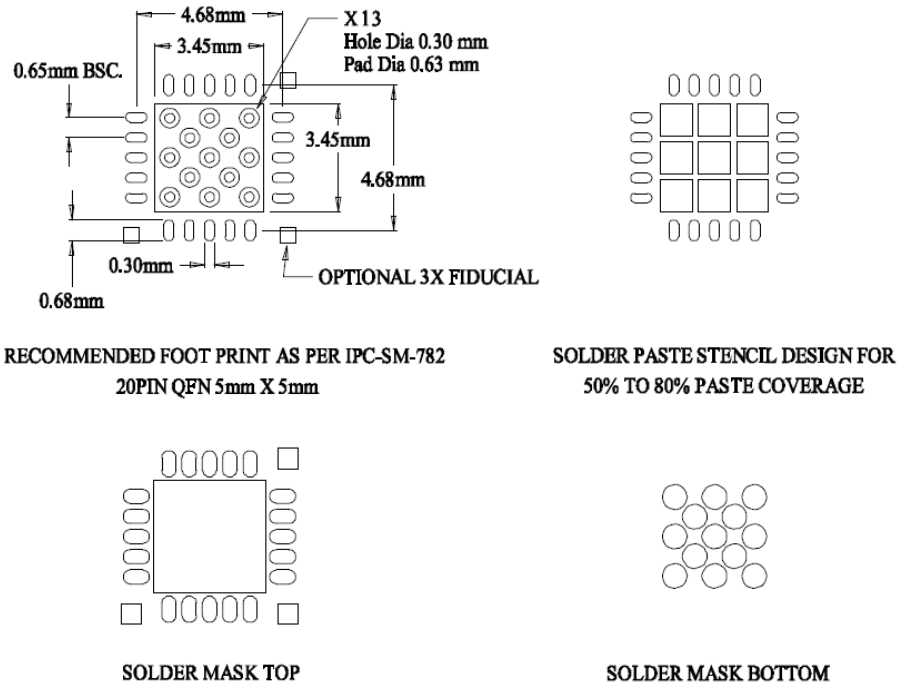

Figure 4 MT1570 Solder Footprint

CONTACT AND ORDERING INFORMATION

MT1570 DOCSIS 3.0 Upstream Amplifier

