

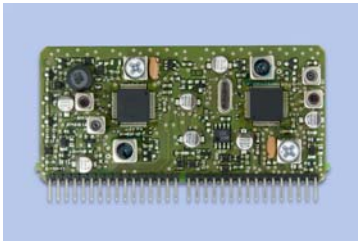

MT1467 AM/FM DOUBLE TUNER MODULE

PRODUCT BRIEF

The MT1467 tuner modules are designed for high-end automobile radios and entertainment system.



MT1467 Tuner Module

The MT1467 AM/FM Double Tuner Module is designed specifically for high-end automotive radio and entertainment systems. It is optimized to meet the performance, market and pricing demands of automotive customers.

To maximize sensitivity and minimize dropouts due to multipath interference, the MT1467 module incorporates one AM tuner and two independent FM tuner sections to support a high-performance phase diversity function. The 10.7 MHz IF output can interface readily with a dedicated DSP (e.g. Philips SAF 7730) to form a DSP-based digital AM/FM radio system.

While both FM tuners receive the same frequency in “phase diversity” mode, the FM tuners can also be set to different frequencies to receive a RDS channel in the background while listening to another station. An AF sample-and-hold interface for the external DSP enables inaudible checking of alternative frequencies within the RDS network.

The MT1467 module provides a RF AGC with a closed loop control and adjustable thresholds. A keyed AGC function is implemented to prevent receiver desensitization due to erroneous AGC response. The IF AGC is controlled by the external DSP. Furthermore the module features automatic alignment for the tracking filters and the image rejection filters. All tuner functions and parameters can be controlled via a serial bus interface.

HD Radio™ (IBOC) capability is optional. Versions for special AM (LW/MW/SW) and FM bands (Europe, USA, Japan) are also available. The MT1467 module is designed specifically for typical automotive operating conditions. It fully complies with RoHS requirements.

APPLICATIONS

- High-end automotive entertainment system requiring digital IF
- HD Radio

FEATURES

FM

- VCO switch for phase diversity applications
- Passive FM pre-stage with auto aligned tracking filter
- Supports inaudible RDS updating
- Image reject mixers
- Keyed AGC selectable
- Digital auto alignment of tracking filters

AM

- Up-conversion
- AM Dual AGC (Cascode and PIN)
- 1st stage ceramic filtering

GENERAL

- All functions controlled by serial bus
- Balanced IF outputs
- High integration and fully shielded housing
- On-board EEPROM
- Variable IF output gain
- Lead-free and RoHS compliant

MT1467 AM/FM DOUBLE TUNER MODULE
PRODUCT BRIEF

RECOMMENDED OPERATING CONDITIONS

PARAMETER	MIN	TYP	MAX	UNIT
8.5 V Power Supply				
Current AM mode		65		mA
Current FM mode		58		mA
Voltage		8.5		V
5 V Power Supply				
Current AM mode		40		mA
Current FM mode		30		mA
Voltage		5		V
Operating temperature range	-40		85	°C
Storage temperature	-40		95	°C

INPUT/OUTPUT CHARACTERISTICS

PARAMETER	MIN	TYP	MAX	UNIT
Antenna Input AM mode				
Input Capacitance, AGC inactive		60		pF
Input Conductance, AGC inactive		1		mS
Input Conductance, AGC active			3.3	mS
Antenna Input FM mode				
Input Impedance, AGC inactive		50		Ω
VSWR, AGC inactive			4	
Input Resistance, AGC active	10			Ω
AGC Buffer Output		500		μA
Keyed AGC Input	0.4		1.4	V
SDA	SDA and SCL HIGH and LOW levels are specified according to a 3.3V serial bus. The bus pins also tolerate thresholds of a 5 V bus.			
SCL				
Intermediate Frequency Output		10.7		MHz
Max. balanced output Voltage		1.4		V
Output resistance		500		Ω
AF Sample Output*		1.2		mA
AF Hold Output*		1.2		mA
Bus enable				
LOW-level input voltage	-0.3		1	V
HIGH-level input voltage	2		5.3	V

* Open collector output with maximum sink current; no internal pull up resistor

DIMENSIONS*

PARAMETER	MEASUREMENT	UNIT
Length	88	mm
Width	48	mm
Height	13	mm

*All inputs/outputs via pins; number of pins is 2x16; pin grid is 2.54 mm

ELECTRICAL CHARACTERISTICS*

PARAMETER	MIN	TYP	MAX	UNIT
Receiving frequency range (depends on version)				
AM mode USA	520		1.720	kHz
FM mode USA	87.9		107.9	MHz
AM MW mode Europe	531		1.602	kHz
FM mode Europe	87.5		108	MHz
AM Parameters				
Sensitivity: RF level for 26dB S+N/N		30		dBμV
S+N/N at RF input = 60dBμV		54		dB
IF rejection (10.7MHz)		75		dB
Image rejection IF1 = tuned frequency + 21.4MHz		80		dB
FM Parameters				
Sensitivity: RF level for 26dB S+N/N		-2		dBμV
S+N/N (Mono) at RF input = 60dBμV		62		dB
IF rejection (10.7MHz)		100		dB
Image rejection IF1 = tuned frequency + 21.4 MHz		55		dB
AM suppression		70		dB
Distortion at RF level = 60dBμV		0.05		%
Selectivity ± 200 kHz		65		dBμV

*Electrical characteristics measured with Philips backend DSP SAF7730 and antenna dummy

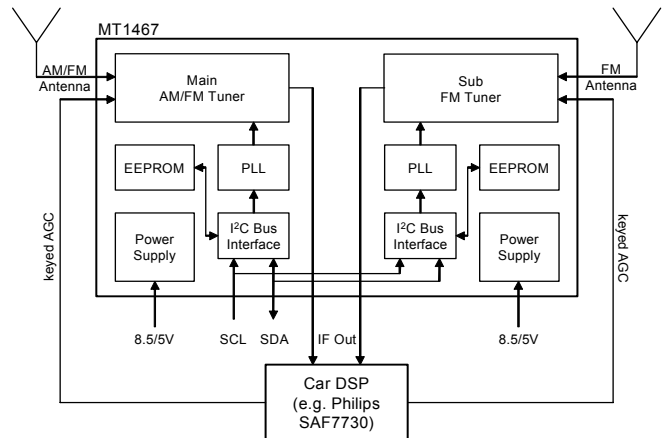

MT1467 Block Diagram



MicroTune, Inc., 2201 Tenth Street, Plano, TX 75074, USA

Tel: +1-972-673-1600, Fax: +1-972-673-1602, E-mail: sales@microtune.com, Web site: www.microtune.com

For a detailed list of office locations, sales offices, and sales representatives, visit our Web site at www.microtune.com

The information in this document is believed to be accurate and reliable. MicroTune assumes no responsibility for any consequences arising from the use of this information, nor from any infringement of patents or the rights of third parties which may result from its use. No license is granted by implication or otherwise under any patent or other rights of MicroTune. The information in this publication replaces and supersedes all information previously supplied, and is subject to change without notice. The customer is responsible for assuring that proper design and operating safeguards are observed to minimize inherent and procedural hazards. MicroTune assumes no responsibility for applications assistance or customer product design.

The devices described in this document are not authorized for use in medical, life-support equipment, or any other application involving a potential risk of severe property or environmental damage, personal injury, or death without prior express written approval of MicroTune. Any such use is understood to be entirely at the user's risk. MicroTune is a registered trademark of MicroTune, Inc. MicroTuner, MicroStreamer, VideoCaster, DataCaster, ClearTune, and the MicroTune logo are trademarks of MicroTune, Inc. All other trademarks belong to their respective companies.

MicroTune's products are protected by one or more of the following U.S. patents: 5,625,325; 5,648,744; 5,717,730; 5,737,035; 5,739,730; 5,805,988; 5,847,612; 6,100,761; 6,104,242; 6,163,684; 6,169,569; 6,172,378; 6,177,964; 6,211,745; 6,218,899; 6,269,778; 6,310,387; 6,323,736; 6,355,537; 6,429,502; 6,462,327; 6,535,068; 6,580,313; 6,608,522; 6,631,257; 6,714,776; 6,725,463; 6,744,308; 6,771,124; 6,784,945; 6,804,099; 6,888,406; 6,891,435; 6,906,594; 6,909,886; 6,919,774; 6,920,182; 6,922,556; 6,963,478; 6,973,288; 6,993,310; 7,035,614; 7,078,960; 7,079,195; 7,164,899; 7,171,176; D469,742 and additional patents pending or filed.