



M I C R O T U N E ®

RF SILICON AND SUBSYSTEMS SOLUTIONS
FOR BROADBAND COMMUNICATIONS AND AUTOMOTIVE ELECTRONICS

MT2067 SINGLE-CHIP AUTOMOTIVE BROADBAND TUNER

PRELIMINARY PRODUCT BRIEF

The MT2067 is an advanced 3.3V single-chip automotive broadband tuner for analog and digital terrestrial standards worldwide



MT2067 Single-Chip Automotive Tuner

PRELIMINARY

The MicroTuner™ MT2067 is an advanced, single-chip tuner, optimized for terrestrial television reception in an automotive environment.

The tuner is capable of receiving frequencies in the 44 MHz to 862 MHz range and supports multiple analog and digital terrestrial television standards including DVB-T, DTMB, ATSC and ISDB-T. A selected channel is down-converted to a standard intermediate frequency (IF) between 30 MHz and 60 MHz.

The MT2067 utilizes an advanced dual-conversion architecture that eliminates the need for external tracking filters. This is achieved by an integrated pre-selection filter at the RF input, low in-band emissions and outstanding image rejection.

The MT2067 has a high level of integration to keep the total bill of materials (BOM) low. Offering a programmable buffered reference frequency output the crystal can be shared with the demodulator or another MT2067 in order to support multi-tuner diversity receivers.

In addition, the MT2067 integrates a spur-avoidance technology, which enables high-performance in multi-tuner architectures by preventing interference between the tuners. The integrated LNA ensures excellent system sensitivity and an innovative architecture enables an automatic gain control (AGC) range of more than 100 dB.

The MT2067 is designed for automotive temperature ranges and is qualified in accordance with AEC-Q100.

APPLICATIONS

- Car TV receivers for analog and/or digital terrestrial TV standards

FEATURES

- 44 MHz to 862 MHz input frequency range
- Compatible with DVB-T, DTMB, ISDB-T, ATSC, NTSC, PAL, SECAM and other terrestrial television standards
- 3.3V power supply
- No active external components required
- Standard IF output works seamlessly with analog and digital demodulators
- Dual-conversion architecture with additional power saving modes
- Integrated RF pre-filter (ClearTune™) and first IF filter
- Buffered reference frequency output
- Single-ended RF input reduces BOM by eliminating input balun
- Alignment free
- Integrated loop-through function for background tuner support
- Integrated power level detectors for closed loop RF AGC
- Integrated IF variable gain amplifier for direct connection to digital demodulator
- Capable of driving cascaded SAW filters with a built-in fixed gain IF buffer amplifier
- Can drive two IF SAW filters in parallel for hybrid analog/digital applications
- Extended operational temperature range
- Designed for qualification according to AEC-Q100 standard
- 48 pin, 7 mm x 7 mm QFN package

M I C R O T U N E

MT2067 SINGLE-CHIP AUTOMOTIVE BROADBAND TUNER

PRELIMINARY PRODUCT BRIEF

RECOMMENDED OPERATING CONDITIONS

PARAMETER	MIN	TYP	MAX	UNIT
Supply voltage (Vcc)	3.15	3.3	3.45	V
Supply voltage ripple			25	mVp-p
Operating junction temperature			125	°C
Operation temperature range	-40		+85	°C
Serial control clock			400	kHz

ABSOLUTE MAXIMUM RATINGS

PARAMETER	MIN	MAX	UNIT
Supply voltage (Vcc)		3.6	V
Storage temperature range	-50	+150	°C
Lead-free solder temperature (soldering 5 seconds, x3)		+260	°C
Input voltage	-0.3	VCC +0.3	V

TUNER ELECTRICAL CHARACTERISTICS

PARAMETER	MIN	TYP	MAX	UNIT
Power Supply				
Active current		320		mA
RF Signal Path				
Input frequency range	44		862	MHz
Noise figure		5.5	6	dB
Terminal voltage gain		43		dB
AGC range		60	67	dB
Image rejection	55	70		dBc
LO phase noise (1 kHz)		-80		dBc/Hz
LO phase noise (10 kHz)		-87		dBc/Hz
LO phase noise (100 kHz)		-106		dBc/Hz
LO1/LO2 step size		250/62.5		kHz
IF VGA				
Frequency range	30		60	MHz
Output voltage swing		1.0		Vp-p
Maximum terminal voltage gain		52		dB
Variable Gain Range		40		dB
IF Amp				
Frequency range	30		60	MHz
Output voltage swing		1.0		Vp-p
Maximum terminal voltage gain		11, 17, 23		dB

PRELIMINARY

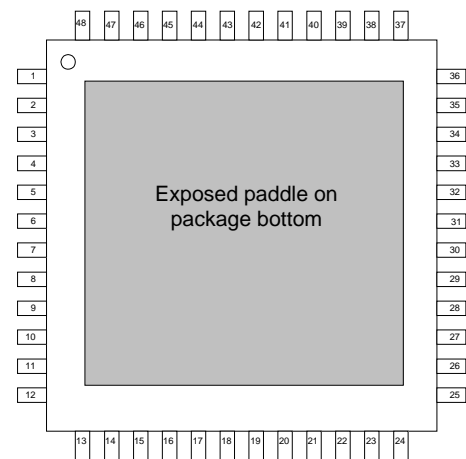

MT2067 Pin Diagram

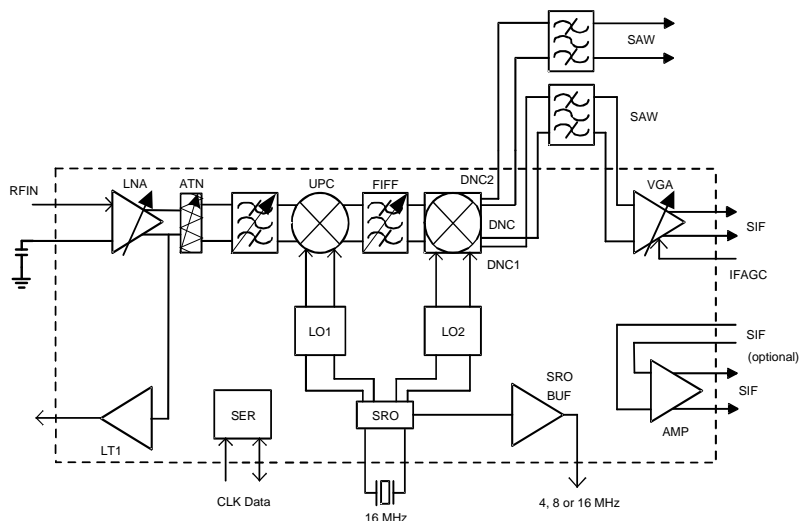

MT2067 Block Diagram



Microtune, Inc., 2201 10th Street, Plano, TX 75074, USA

Tel: +1-972-673-1600, Fax: +1-972-673-1602, E-mail: sales@microtune.com, Web site: www.microtune.com

For a detailed list of office locations, sales offices, and sales representatives, visit our web site at www.microtune.com

Microtune believes that the information in this document is accurate and reliable, as of the date of this document. Microtune assumes no responsibility for any consequences arising from the use of this information, nor from any infringement of patents or the rights of third parties which may result from its use. No license is granted by implication or otherwise under any patent or other rights of Microtune. The information in this publication replaces and supersedes all information previously supplied, and is subject to change without notice. The customer is responsible for assuring that proper design and operating safeguards are observed to minimize inherent and procedural hazards. Microtune assumes no responsibility for applications assistance or customer product design.

The devices described in this document are not authorized for use in medical, life-support equipment, or any other application involving a potential risk of severe property or environmental damage, personal injury, or death without prior express written approval of Microtune. Any such use is understood to be entirely at the user's risk.

Microtune is a registered trademark of Microtune, Inc. MicroTuner, MicroStreamer, VideoCaster, DataCaster, ClearTune, and the Microtune logo are trademarks of Microtune, Inc. All other trademarks belong to their respective companies.

Microtune's products are protected by one or more of the following U.S. patents: 5,625,325; 5,648,744; 5,717,730; 5,737,035C1; 5,739,730; 5,805,988; 5,847,612; 6,100,761; 6,104,242; 6,163,684; 6,169,569; 6,172,378; 6,177,964; 6,211,745; 6,218,899; 6,268,778; 6,310,387; 6,323,736; 6,355,537; 6,429,502; 6,462,327; 6,535,068; 6,580,313; 6,608,522; 6,631,257; 6,714,776; 6,725,463; 6,744,308; 6,771,124; 6,784,945; 6,804,099; 6,888,406; 6,891,435; 6,906,594; 6,909,886; 6,919,774; 6,920,182; 6,922,556; 6,963,478; 6,973,288; 6,993,310; 7,035,614; 7,039,062; 7,078,960; 7,079,195; 7,119,834; 7,164,899; 7,171,176; 7,184,724; 7,190,942; 7,190,943; 7,242,918; 7,274,410; 7,304,689; 7,304,533; 7,304,393; 7,313,201; 7,319,849; 7,333,793; 7,359,686; 7,369,827; 7,376,407; 7,388,437; 7,436,262; 7,444,126; 7,446,692; D469,742 and additional patents pending or filed.

Microtune's products are protected by one or more of the following International patents:

United Kingdom: 1225700; 1532732; Germany: 602298894.6; 60313621.4; Netherlands: 1225700; 1532732; France: 1225700; 1532732; and additional patents pending or filed.

Entire contents Copyright © 1996 - 2009 Microtune, Inc.

011609