



M I C R O T U N E ®

RF SILICON AND SUBSYSTEMS SOLUTIONS
FOR BROADBAND COMMUNICATIONS AND AUTOMOTIVE ELECTRONICS

MT1120 AUTOMOTIVE AM/FM ANTENNA AMPLIFIER SUBSYSTEM

PRODUCT BRIEF

The MT1120 is a highly integrated
and complete RF amplifier
subsystem for active AM/FM
antennas



MT1120 High Performance Automotive AM/FM
Amplifier Subsystem

The MT1120 is an advanced, low-power, highly integrated single-chip amplifier IC specifically designed for automotive AM/FM antenna systems requiring low noise and very low distortion. Additionally, the MT1120 integrates two true-RMS power detectors and two uncommitted op-amps in order to realize an AGC function for AM and FM by simply adding external PIN diodes. The thresholds of the AM and FM AGC function are variable and can be set according to the application requirements. The on-chip 2.55V temperature compensated reference generator and high output voltage op-amp combine to form a low-cost, reliable, automotive-capable power supply which can be directly derived from the car battery.

The MT1120 is capable of amplifying signals with frequencies in the 0.15 MHz to 30 MHz range for AM and 76 MHz to 165 MHz range for FM. External components determine the gain of the AM and FM amplifiers and can also be modified to extend the operating frequency of the MT1120.

The AM amplifier uses a highly sophisticated design technology in order to reach low noise, very low distortion, high input impedance and its capability to drive very low output impedance. The FM amplifier is matched to 50 ohms and is specially designed to perform with very low noise and distortion.

The small 28-pin QFN package of the MT1120 and the requirement for minimal external components enables a compact, cost-effective solution fulfilling automotive requirements.

APPLICATIONS

- In-glass antennas
- Active roof antennas
- Other active AM/FM antenna systems

FEATURES

- AM input frequency range 0.15 MHz to 30 MHz supports AM, DRM and HD Radio standards in the longwave, midwave and shortwave band
- FM input frequency range 76 MHz to 165 MHz supports FM and HD Radio standards in the FM and weather band
- Fully integrated amplifiers for AM and FM
- Fully integrated RMS level detectors and general purpose op-amps (PIN-diode drivers) for easy implementation of AGC functions for AM and FM
- On-chip reference voltage generator and high output voltage op-amp builds a reliable low-cost voltage regulator function
- Low noise
- Low power consumption
- Ultra low distortion
- Very high AM input impedance
- Very small package
- Highly sophisticated temperature compensation design technology to support the extended automotive ambient temperature range from -40° to 115°C.
- Integrated ESD protection
- Minimal external components
- 5x5mm 28-pin QFN package

M I C R O T U N E

MT1120 AUTOMOTIVE AM/FM AMPLIFIER SUBSYSTEM

PRODUCT BRIEF

RECOMMENDED OPERATING CONDITIONS

PARAMETER	MIN	TYP	MAX	UNIT
Input frequency range AM	0.15		30	MHz
Input frequency range FM	76		165	MHz
Supply voltage	5.7	6	6.3	V
Current consumption	74	89	103	mA

ABSOLUTE MAXIMUM RATINGS

PARAMETER	MIN	MAX	UNIT
Supply voltage		6.5	V
Storage temperature range	-40	+150	°C
Operating Junction Temperature		+145	°C
Lead temperature (soldering 5 seconds, lead-free solder)		+260	°C
Input voltage	-0.7	VCC +0.5	V

IC DESIGN PARAMETER

PARAMETER	TYP	UNIT
FM Section		
Input/Output impedance	50	Ω
AM Section		
Input resistance	1	MΩ
Input capacitance	10	pF

AMPLIFIER ELECTRICAL CHARACTERISTICS

PARAMETER	MIN	TYP	MAX	UNIT
FM Signal Path				
FM gain	3		13	dB
OIP3 FM		143		dBμV
FM noise figure at 3dB gain at 98 MHz		2.2		dB
AM Signal Path				
AM gain	0		14	dB
OIP3 AM		153		dBμV
OIP2 AM		192		dBμV
AM output noise at 6dB gain (BW=9KHz) @ 1 MHz		-6		dBμV
Op Amps				
Input voltage range	0		6	V
Output voltage range	0		6	V
HV-amp input voltage range	0		6	V
HV-amp output voltage range	0		25	V
Output sink current (HV-amp)		10		mA
Reference				
Output voltage		2.55		V

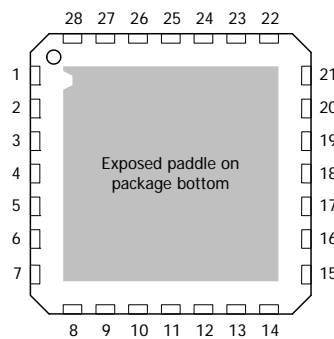

MT1120 Pin Diagram

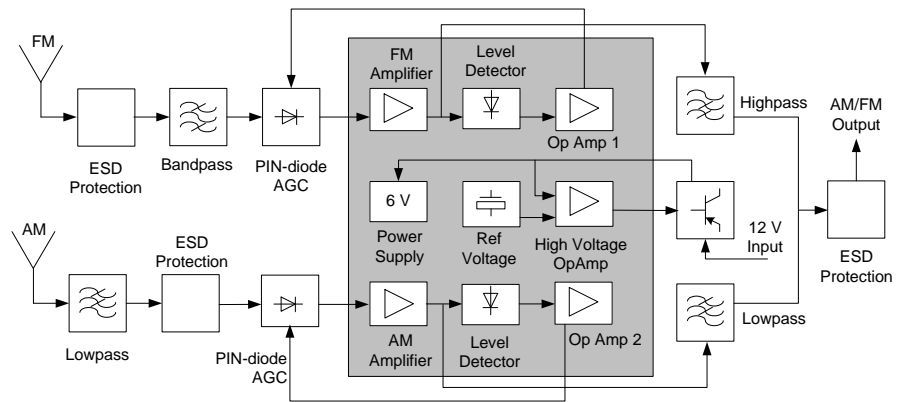

MT1120 Block Diagram



Microtune, Inc., 2201 10th Street, Plano, TX 75074, USA

Tel: +1-972-673-1600, Fax: +1-972-673-1602, E-mail: sales@microtune.com, Web site: www.microtune.com

For a detailed list of office locations, sales offices, and sales representatives, visit our web site at www.microtune.com

Microtune believes that the information in this document is accurate and reliable, as of the date of this document. Microtune assumes no responsibility for any consequences arising from the use of this information, nor from any infringement of patents or the rights of third parties which may result from its use. No license is granted by implication or otherwise under any patent or other rights of Microtune. The information in this publication replaces and supersedes all information previously supplied, and is subject to change without notice. The customer is responsible for assuring that proper design and operating safeguards are observed to minimize inherent and procedural hazards. Microtune assumes no responsibility for applications assistance or customer product design.

The devices described in this document are not authorized for use in medical, life-support equipment, or any other application involving a potential risk of severe property or environmental damage, personal injury, or death without prior express written approval of Microtune. Any such use is understood to be entirely at the user's risk.

Microtune is a registered trademark of Microtune, Inc. MicroTuner, MicroStreamer, VideoCaster, DataCaster, ClearTune, and the Microtune logo are trademarks of Microtune, Inc. All other trademarks belong to their respective companies.

Microtune's products are protected by one or more of the following U.S. patents: 5,025,325; 5,648,744; 5,717,730; 5,737,035C1; 5,739,730; 5,805,988; 5,847,612; 6,100,761; 6,104,242; 6,163,684; 6,169,569; 6,172,378; 6,177,964; 6,211,745; 6,218,899; 6,268,778; 6,310,387; 6,325,736; 6,355,537; 6,429,502; 6,462,327; 6,555,068; 6,580,313; 6,608,322; 6,631,257; 6,714,776; 6,725,463; 6,744,308; 6,771,124; 6,784,945; 6,804,099; 6,888,406; 6,891,435; 6,906,594; 6,909,886; 6,919,774; 6,920,182; 6,922,556; 6,963,478; 6,973,288; 6,993,310; 7,035,614; 7,039,062; 7,078,960; 7,079,195; 7,119,834; 7,164,899; 7,171,176; 7,184,724; 7,190,942; 7,190,943; 7,242,918; 7,274,410; 7,304,689; 7,304,533; 7,304,393; 7,313,201; D469,742 and additional patents pending or filed.

Microtune's products are protected by one or more of the following International patents:

United Kingdom: 1532732; Germany: 60313621.4; Netherlands: 1532732; France: 1532732; and additional patents pending or filed.

Entire contents Copyright © 1996 - 2008 Microtune, Inc.

011108